

visionary[™]
DESIGNS

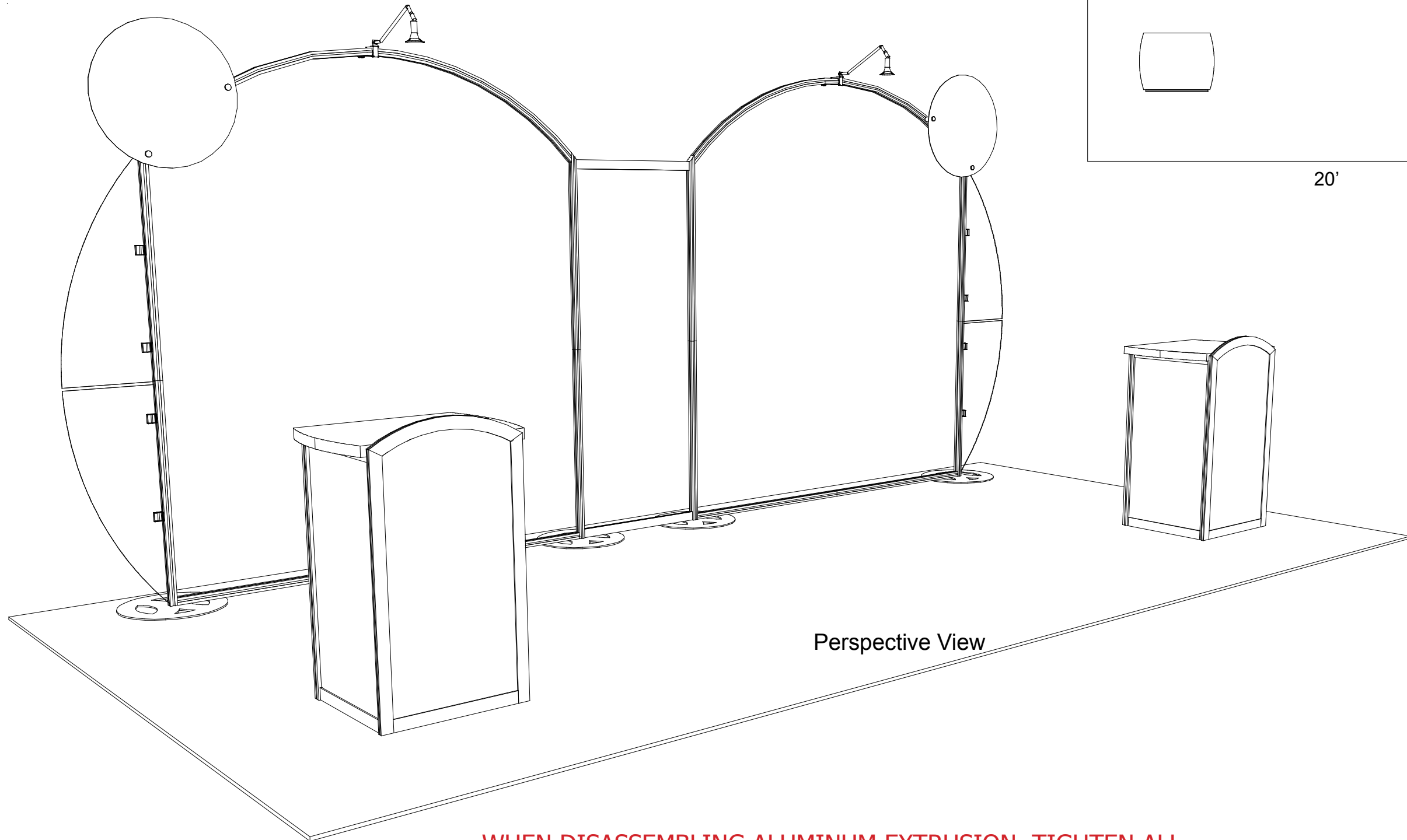

Perspective View

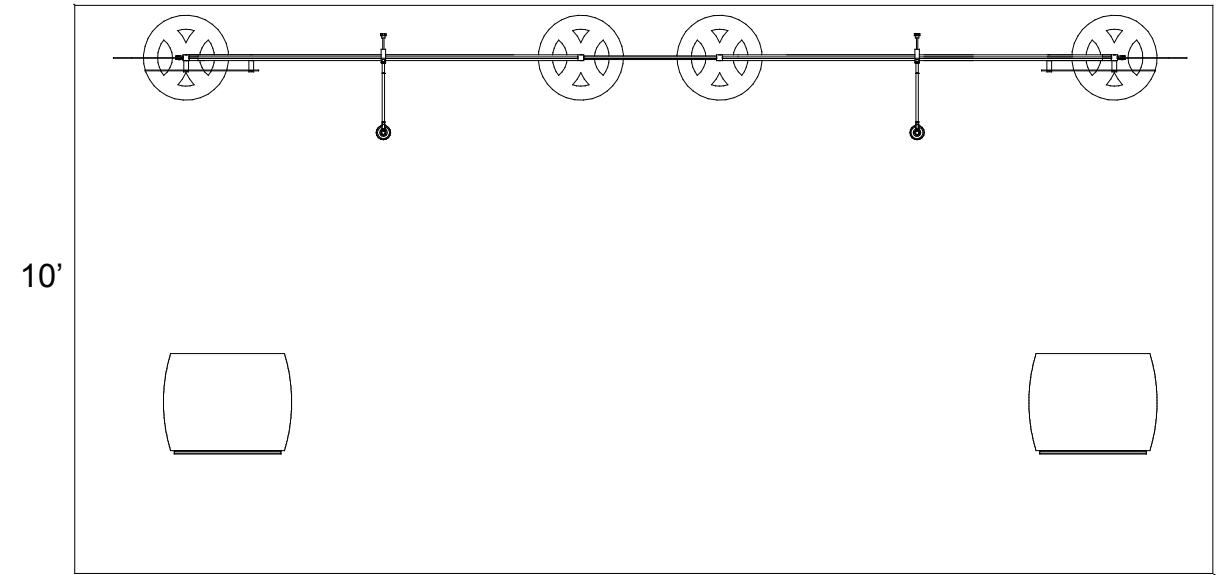

20' Plan View

WHEN DISASSEMBLING ALUMINUM EXTRUSION, TIGHTEN ALL SETSCREWS AND LOCKS TO PREVENT LOSS DURING SHIPPING



General Setup Instructions

- Read entire setup instruction manual prior to unpacking parts and pieces.
- The setup instructions are created specifically for this configuration.
- Setup instructions are laid out sequentially in steps, including exploded views with detailed explanation for assembly.

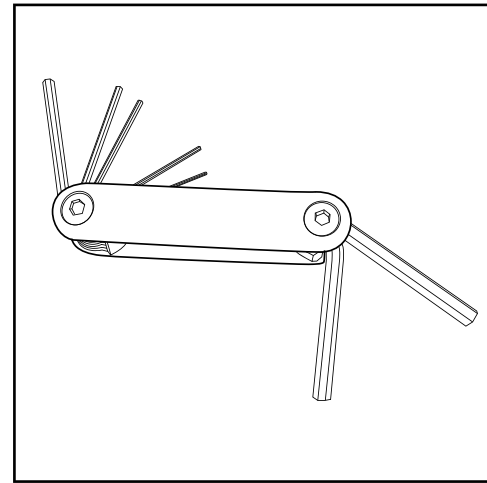

Hex Tool - Essential for Assembly

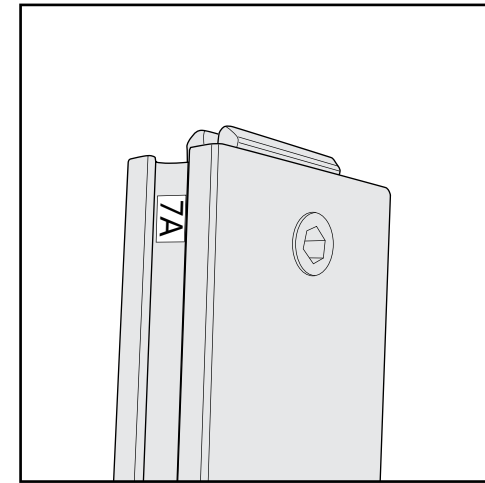

Part Identification - Numbering



Cleaning & Packing

- For Cleaning Metal, Plex, & Laminate Parts: Use a **MILD NON-ABRASIVE** cleanser and soft cloth/paper towel to clean all surfaces.
- Keep exhibit components away from heat and prolonged sun exposure. **Heat and UV exposure will warp and fade components.**
- Retain all provided Packing Materials. All provided packing materials are for ease of repacking & component protection.

Disassembly

- For loss prevention, tighten all setscrews and locks during disassembly

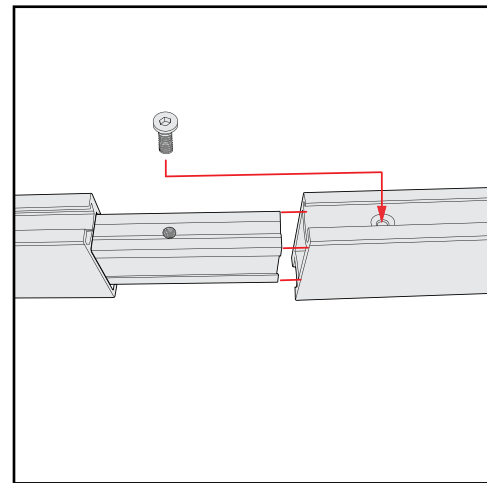

Spline Connection

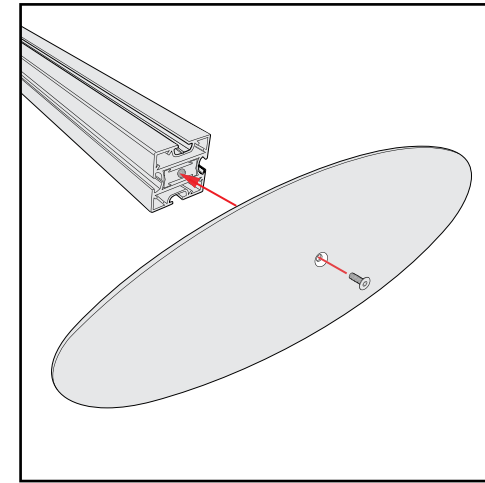

Base Plate & Extrusion Connection



DO NOT USE POWER TOOLS

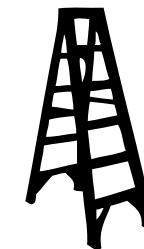

LADDERS OR LIFTS MAY BE REQUIRED

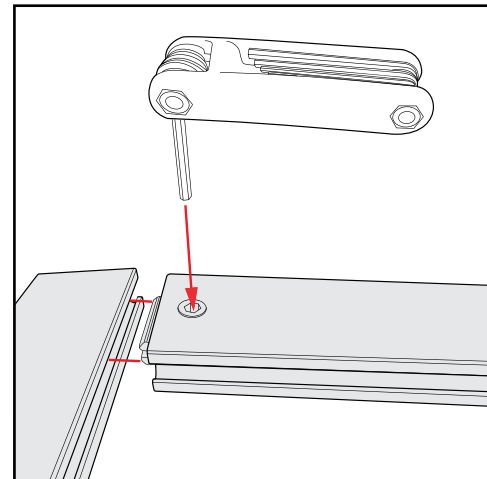

Extrusion & Lock Connection

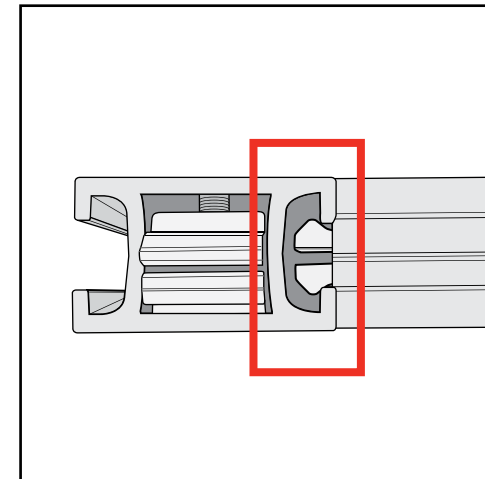

Engaged Lock



ALL CONNECTIONS MUST BE TIGHTLY SECURED

WHEN DISASSEMBLING ALUMINUM EXTRUSION, TIGHTEN ALL SETSCREWS AND LOCKS TO PREVENT LOSS DURING SHIPPING

866.652.2100

Item	Qty.	Description
1A	2	Base Plates
1	1	39" Vertical extrusion
2	1	39" Vertical extrusion top left outside cut
3	1	39" Vertical extrusion
4	1	39" Vertical extrusion top right outside cut
5	1	41" Horizontal extrusion
6	1	41" Horizontal extrusion
7	1	41" Top left curved extrusion
8	1	41" Top right curved extrusion

Steps:

- 1) Attach base plates [1A] to lower verticals [1,3].
- 2) Connect upper verticals [2,4] with connection bars [b].
- 3) Connect horizontals [5,6] with connection bar [a].
- 4) Connect vertical [1/2,3/4] with horizontal assembly [5/6].
- 5) Connect curved extrusions [7,8] with connection bar [a].
- 6) Connect curved assembly [7/8] between verticals [1/2,3/4].
- 7) Attach Velcro Graphic to back of frame as shown.

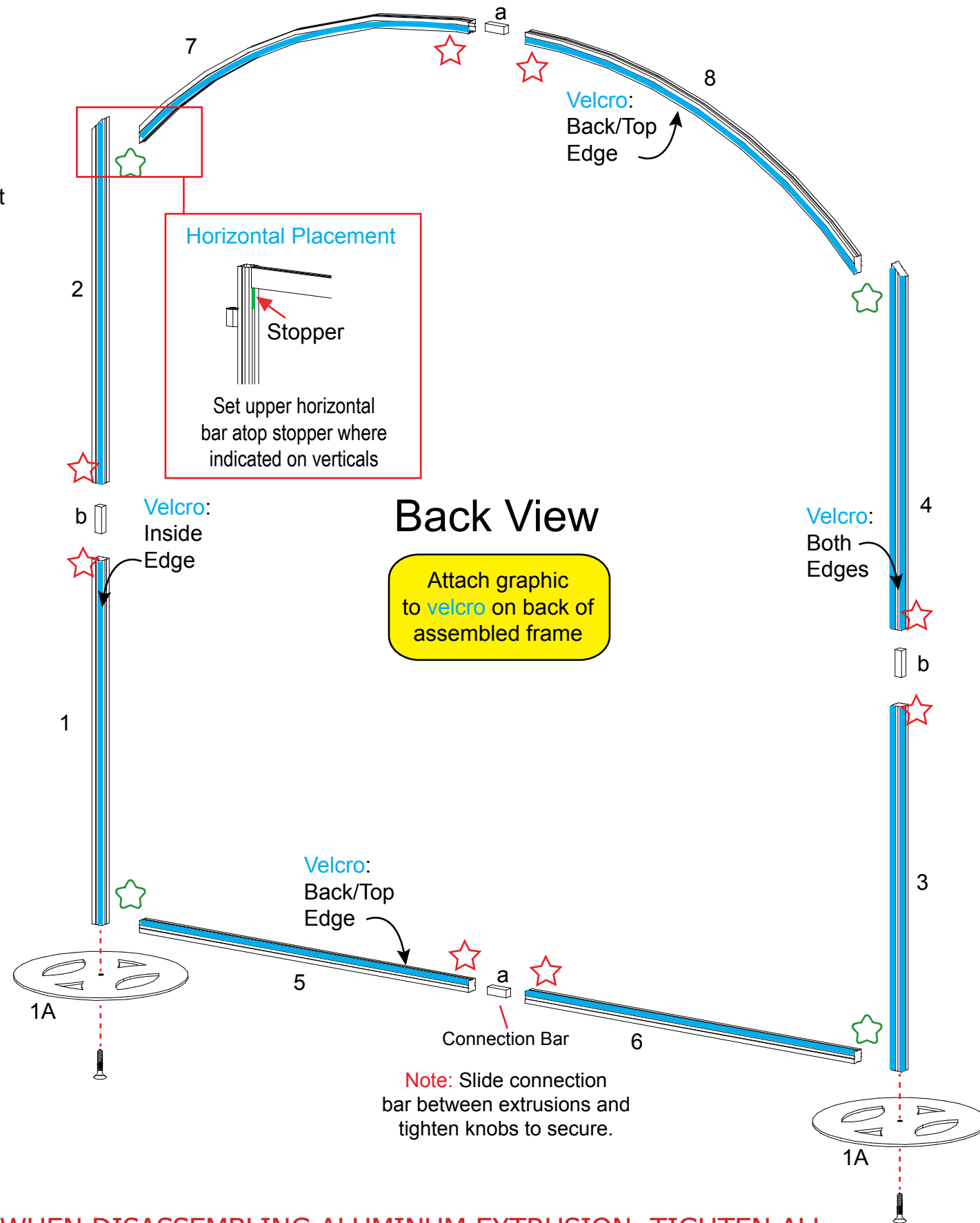

★ indicates location of knobs on BACKSIDE of unit.

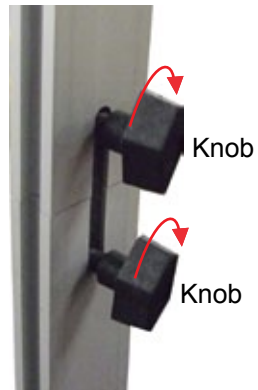

Turn Knob Clockwise to Tighten Lock

Do not over tighten Knobs

★ indicates location of connection lock with knob.

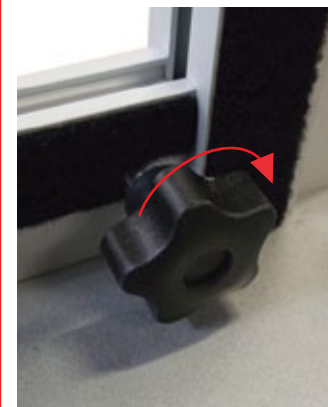

Note: Slide connection bar between extrusions and tighten knobs to secure.

WHEN DISASSEMBLING ALUMINUM EXTRUSION, TIGHTEN ALL SETSCREWS AND LOCKS TO PREVENT LOSS DURING SHIPPING

866.652.2100

Item	Qty.	Description
1A	2	Base Plates
1	1	39" Vertical extrusion
2	1	39" Vertical extrusion top left outside cut
3	1	39" Vertical extrusion
4	1	39" Vertical extrusion top right outside cut
5	1	41" Horizontal extrusion
6	1	41" Horizontal extrusion
7	1	41" Top left curved extrusion
8	1	41" Top right curved extrusion

Steps:

- 1) Attach base plates [1A] to lower verticals [1,3].
- 2) Connect upper verticals [2,4] with connection bars [b].
- 3) Connect horizontals [5,6] with connection bar [a].
- 4) Connect vertical [1/2,3/4] with horizontal assembly [5/6].
- 5) Connect curved extrusions [7,8] with connection bar [a].
- 6) Connect curved assembly [7/8] between verticals [1/2,3/4].
- 7) Attach Velcro Graphic to back of frame as shown.

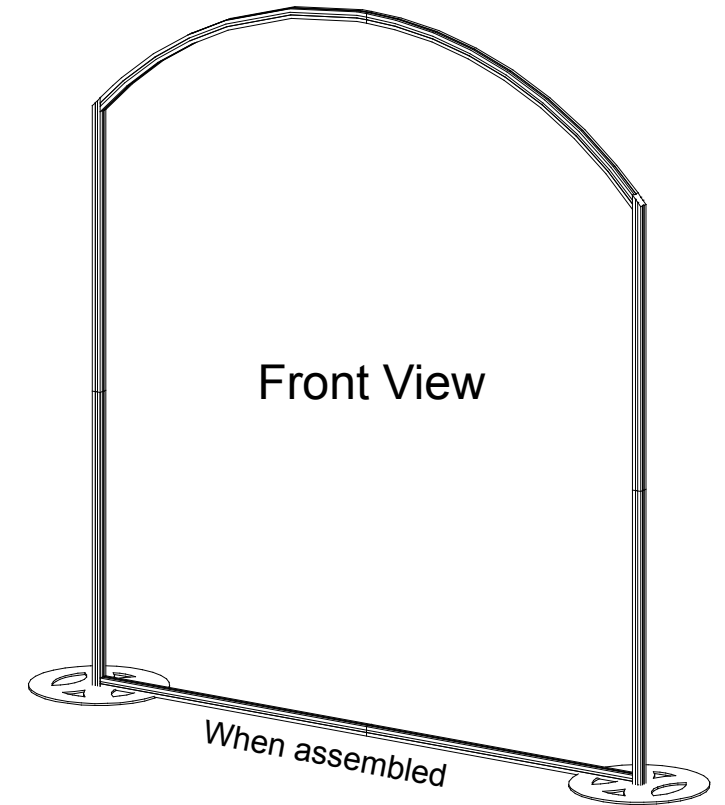
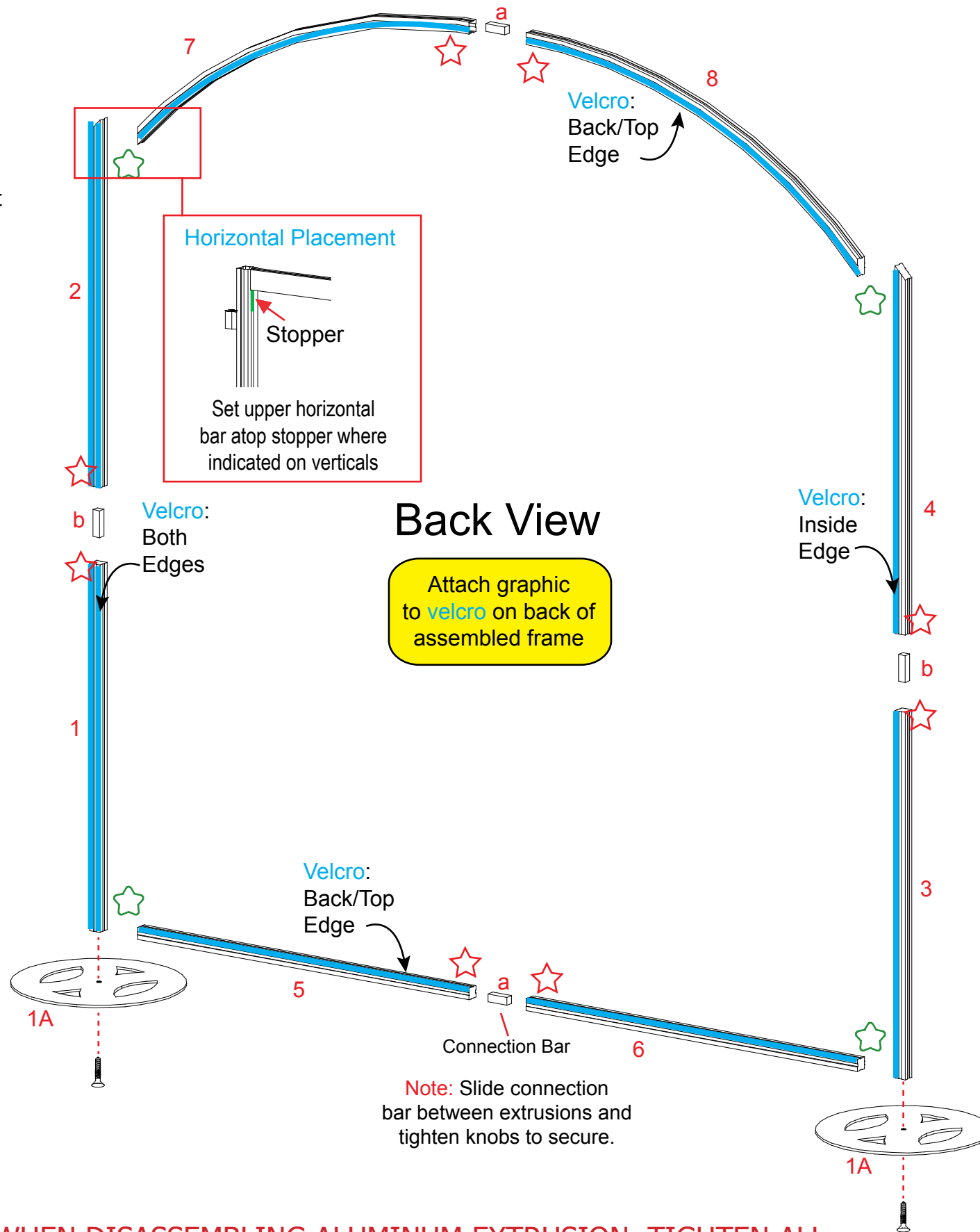
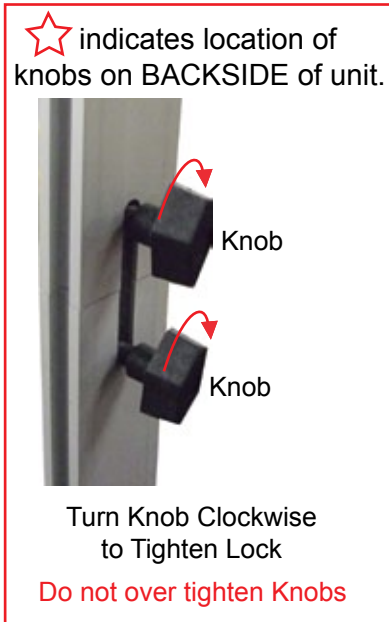

WHEN DISASSEMBLING ALUMINUM EXTRUSION, TIGHTEN ALL SETSCREWS AND LOCKS TO PREVENT LOSS DURING SHIPPING

866.652.2100

Item	Qty.	Description
13	1	28" Horizontal Extrusion
14	1	28" Horizontal Extrusion

Steps:

- 1) Insert [13,14] between left and right side as shown.
- 2) Attach Graphics on back of display.

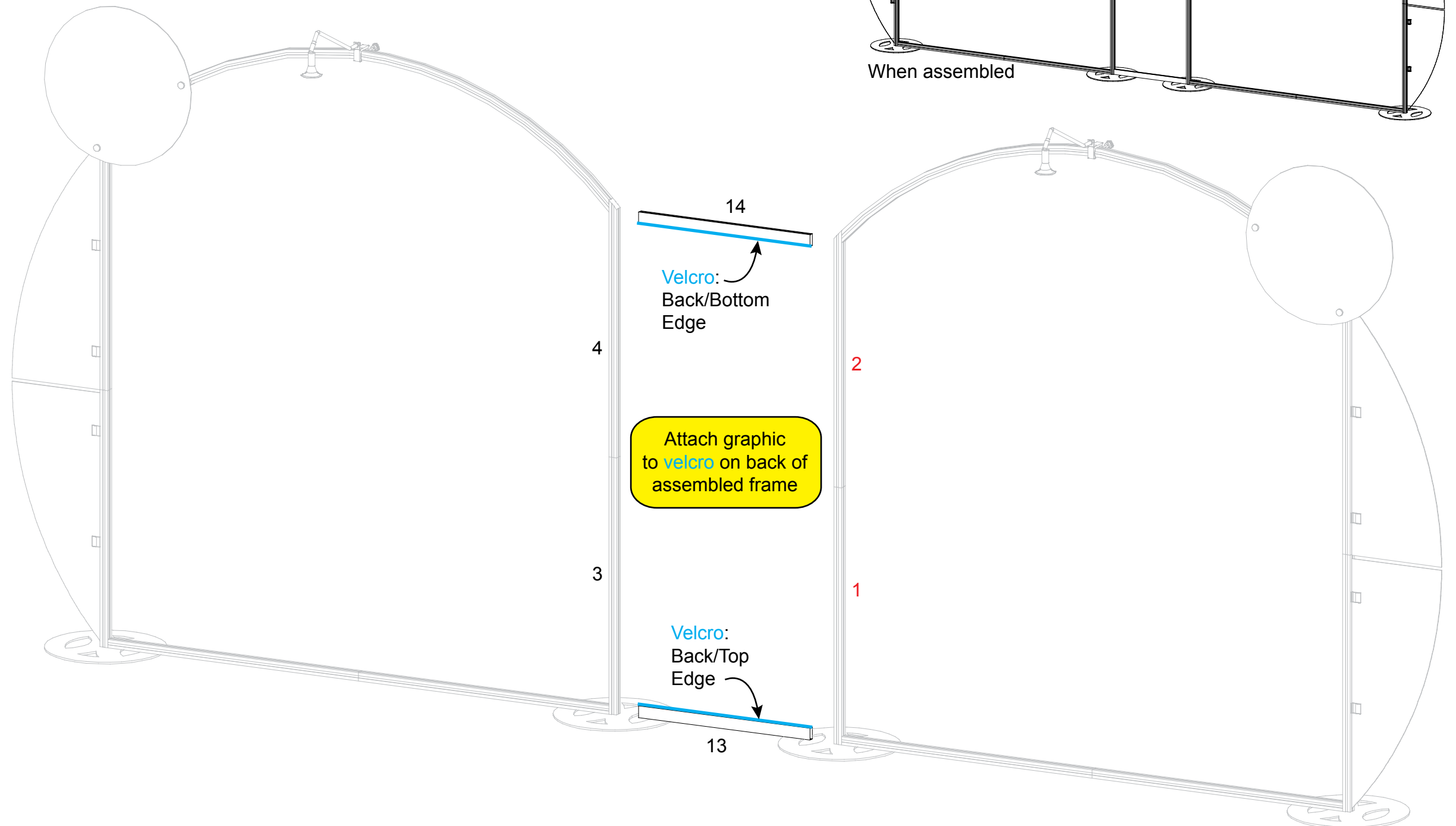
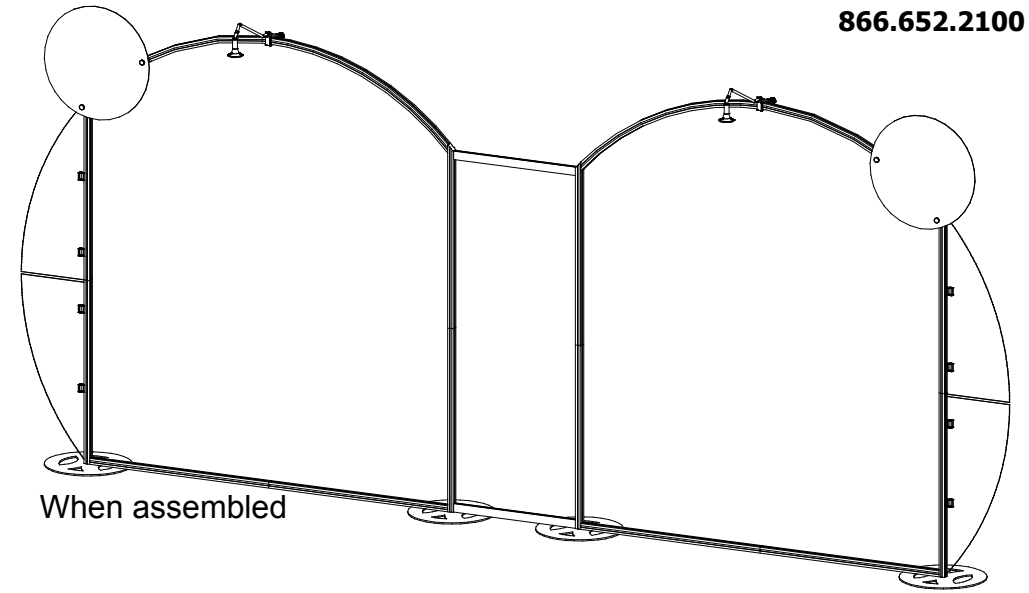

WHEN DISASSEMBLING ALUMINUM EXTRUSION, TIGHTEN ALL SETSCREWS AND LOCKS TO PREVENT LOSS DURING SHIPPING

866.652.2100

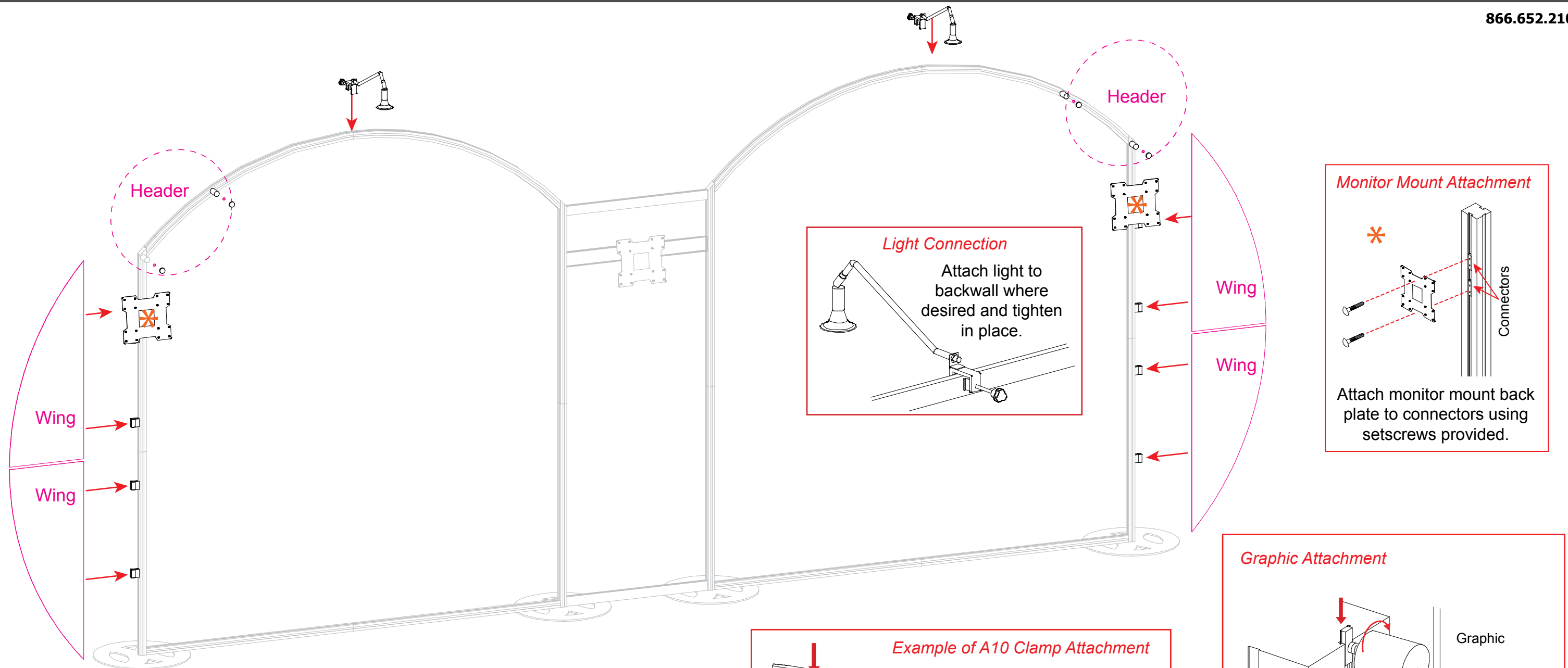

Light Connection

Attach light to backwall where desired and tighten in place.

Monitor Mount Attachment

Connectors

Attach monitor mount back plate to connectors using setscrews provided.

Graphic Attachment

Graphic

Standoff Barrel

Cap

Slide connector on back of standoff barrels into groove of extrusion and twist to secure in place. Secure graphic to standoffs using screw caps.

Example of A10 Clamp Attachment

When desired location is found, tighten set screw to secure.

Slide connector on back of A10 clamp into groove of extrusion.

Tighten knob to secure shelf/wing in place.

- Steps:
- 1) Attach Wings with to A10's as shown in *Example of A10 Clamp Attachment* detail.
 - 2) Attach header graphic as shown in *Graphic Attachment* detail.
 - 3) Connect lights as shown in *Light Connection* detail.
 - 4) Connect monitors as shown in *Monitor Mount Attachment* detail.

WHEN DISASSEMBLING ALUMINUM EXTRUSION, TIGHTEN ALL SETSCREWS AND LOCKS TO PREVENT LOSS DURING SHIPPING

866.652.2100

Item	Qty.	Description
1-2	1ea.	38" Vertical Extrusion w/ cut
3-4	1ea.	38" Vertical Extrusion
5	1	18.9" Horizontal Extrusion
6-7	1ea.	18" Horizontal Extrusion
8	1	20" Horizontal Extrusion
9	1	22.5" Curved Extrusion
10-11	1ea.	18" Horizontal Extrusion
12	1	20" Horizontal Extrusion

Steps:

- 1) Attach lower horizontals [5,6,7,8] between verticals [1,2,3,4] as shown.
- 2) Attach door using pins as shown in *Door Attachment* detail.
- 3) Insert infills as shown.
- 4) Insert [9,10,11,12] between verticals.
- 5) Place internal shelf on top of shelf supports.
- 6) Place counter on top.

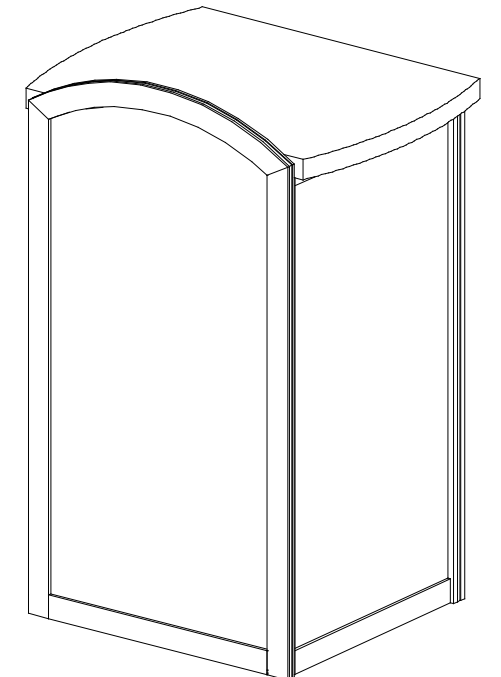
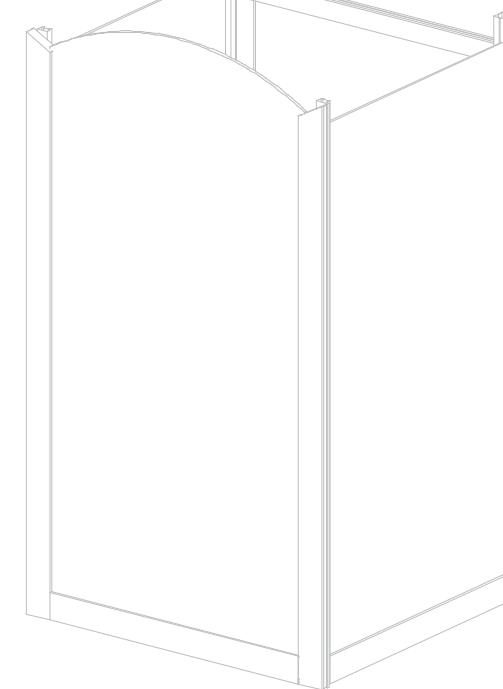
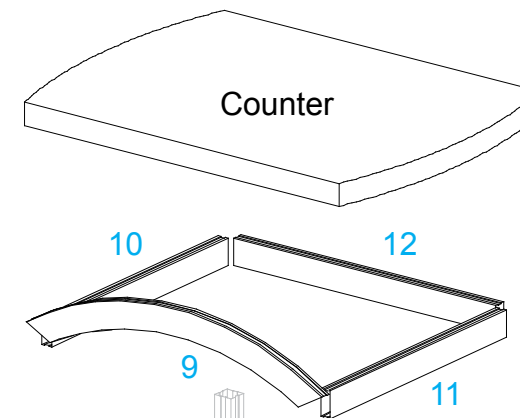
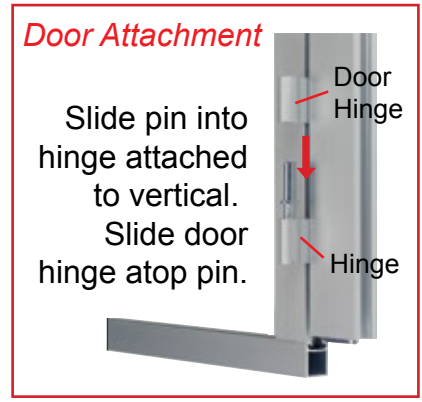
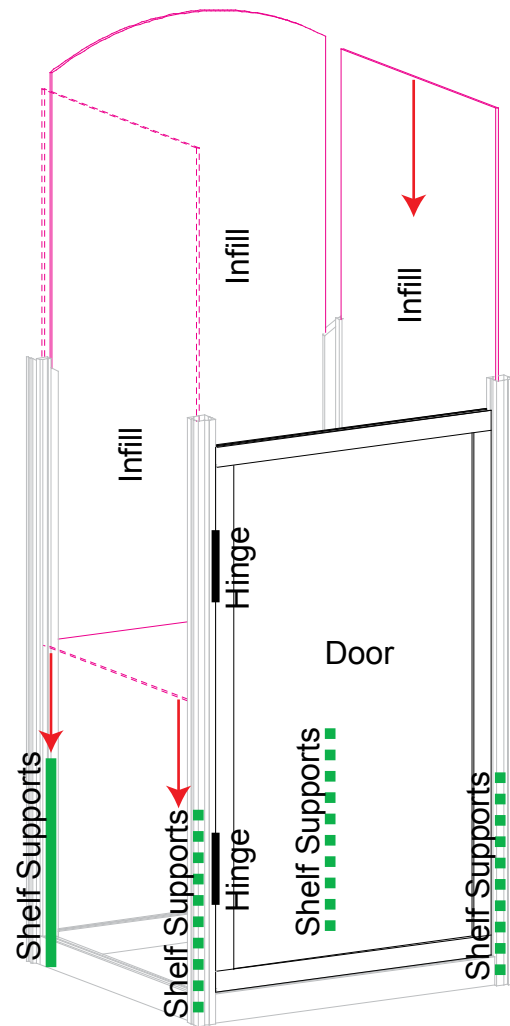
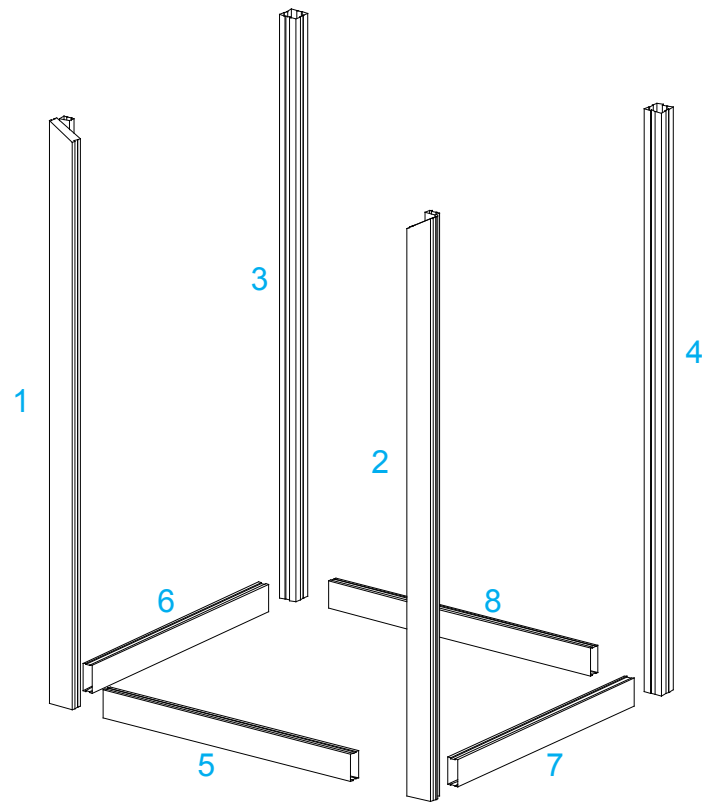

Front Side
When assembled

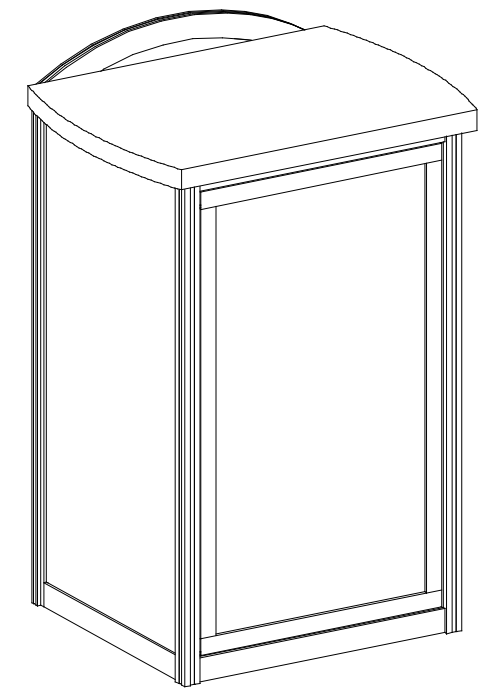

Back Side
When assembled

WHEN DISASSEMBLING ALUMINUM EXTRUSION, TIGHTEN ALL SETSCREWS AND LOCKS TO PREVENT LOSS DURING SHIPPING